

**SNYDER NEIL K & DORIS H**

1299 BLACK FOREST DR  
512984

PLAT: 00002/0833B UNIQ ID 3148  
ID NO:

**Parcel ID: 6653-02-97-7171-**

SPLIT FROM ID

Reval Year: 2021 Tax Year: 2027  
Appraised By 07 on 12/16/2020 24400 FONTANA RIDGE PROP/BLACK FORST/TUSKASAGEE HIGHLND

CARD NO. 1 of 1  
10.2730 AC  
TW-20 CI- FR-TN

SRC= Pictometry Review  
AT- LAST ACTION 20210417

CONSTRUCTION DETAIL		MARKET VALUE								DEPRECIATION		CORRELATION OF VALUE	
USE	MOD	Eff. Area	QUAL	BASE RATE	RCN	EYB	AYB			NORM	0.09000	CREDENCE TO	MARKET
Foundation		3											
Continuous/Footing		5.00	01	01	3,408	168	152.88	537139	2012	2002	% GOOD	91.0	
Sub Floor System		4											
Plywood		8.00											
Exterior Walls		17											
Cedar,Redwood or D-Log Siding		25.00											
Roofing Structure		06											
Irregular/Cathedral		14.00											
Roofing Cover		12											
Metal, Pre-Finish		14.00											
Interior Wall Construction		6											
Custom/Log Interior		32.00											
Interior Floor Cover		12											
Hardwood		10.00											
Heating Fuel		04											
Electric		2.00											
Heating Type		10											
Heat Pump		4.00											
Air Conditioning Type		03											
Central		5.00											
Bedrooms/Bathrooms/Half-Bathrooms		3/3/0											
Bedrooms		15.000											
BAS - 2 FUS - 1 LL - 0													
Bathrooms													
BAS - 1 FUS - 1 LL - 1													
Half-Bathrooms													
BAS - 0 FUS - 0 LL - 0													
Office													
BAS - 0 FUS - 0 LL - 0													
<b>TOTAL POINT VALUE</b>													134.000
BUILDING ADJUSTMENTS													
Quality	5	GOOD/CU	1.25										
Shape/Design	5	Irregular	1.15										
Size	Size	Size	0.87										
TOTAL ADJUSTMENT FACTOR			1.250										
TOTAL QUALITY INDEX			168										

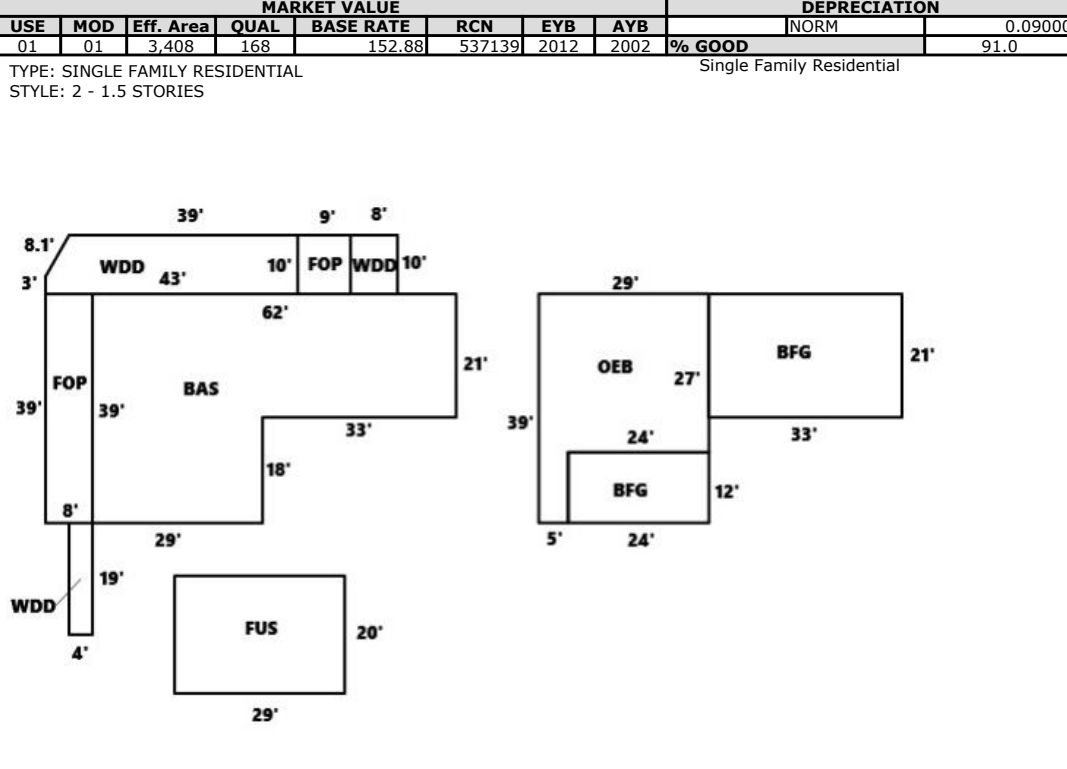

CORRELATION OF VALUE							
DEPR. BUILDING VALUE - CARD	488,800						
DEPR. OB/XF VALUE - CARD							
MARKET LAND VALUE - CARD	90,000						
<b>TOTAL MARKET VALUE - CARD</b>	<b>578,800</b>						
<b>TOTAL APPRAISED VALUE - CARD</b>	<b>578,800</b>						
<b>TOTAL APPRAISED VALUE - PARCEL</b>	<b>578,800</b>						
<b>TOTAL PRESENT USE VALUE - LAND</b>	<b>0</b>						
<b>TOTAL VALUE DEFERRED - PARCEL</b>	<b>0</b>						
<b>TOTAL TAXABLE VALUE - PARCEL \$</b>	<b>578,800</b>						
PRIOR APPRAISAL							
BUILDING VALUE	488,800						
OBXF VALUE	0						
LAND VALUE	90,000						
PRESENT USE VALUE	0						
DEFERRED VALUE	0						
<b>TOTAL VALUE</b>	<b>578,800</b>						
PERMIT							
CODE	DATE NO.						
ROUT: WTRSHD:							
SALES DATA							
OFF. RECORD	DATE	DEED	INDICATE				
BOOK	PAGE	MO	YR	TYPE	O/U	V/I	SALES PRICE
0443	0349	10	2016	W	Q	V	30,000
0450	0670	7	2017	COMD	C	I	0
0351	0152	8	2007		X	V	545,000
0219	0464	11	1998		X	V	0
HEATED AREA 3,247							
NOTES							
GEN: EXCELLENT VIEWS/BH GEN: REMODELED KITCHEN & ADDED 2 CAR FGD, 2018. GEN: PLUS ADDED 580 SQ FT.							

SUBAREA				CODE	QUALITY	DESCRIPTION	COUNT	LTH	WTH	UNITS	UNIT PRICE	ORIG % COND	BLDG #	---	AYB	EYB	DEP SCH	OVR	% COND	OB/XF DEPR. VALUE	
BAS	1,824	100	278853			<b>TOTAL OB/XF VALUE</b>															
BFG	981	035	52438																		
FOP	402	035	21556																		
FUS	580	090	79803																		
OEB	843	055	70936																		
WDD	572	020	17428																		
<b>FIREPLACE</b>	6 - 1		16,125																		
	Massive/Stone																				
<b>SUBAREA TOTALS</b>	5,202		537,139																		

**BLDG DIMENSIONS** BAS=S21W33S18W29N39E62Area:1824;FOP=W8N39E8S39Area:312;WDD=N3NE@60.26-8.06E39S10W43Area:416;WDD=S19W4N19E4Area:76;FOP=E9S10W9N10Area:90;WDD=E8S10W8N10Area:80;BFG=E33S21W33N21Area:693;FUS=E29S20W29N20Area:580;OEB=S39E5N12E24N27W29Area:843;BFG=N12W24S12E24Area:288;TotalArea:5202

LAND INFORMATION																	
HIGHEST AND BEST USE	USE CODE	LOCAL ZONING	FRONTAGE	DEPTH	DEPTH / SIZE	LND MOD	COND FACT	OTHER ADJ/NOTES RF AC LC TO OT	ROAD TYPE	LAND UNIT PRICE	TOTAL LAND UNITS	UNIT TYPE	TOTAL ADJUST	ADJUSTED UNIT PRICE	LAND VALUE	OVERRIDE VALUE	LAND NOTES
SINGLE FAMILY RESIDENTIAL MOUNTAIN VIEW	0121		0	0	1.0000	0	3.0000	+00 +00 +00 +00 +00 2 LOTS/VIEW	RG	30,000.00	1.000	LT	3.000	90,000.00	90000	0	
<b>TOTAL MARKET LAND DATA</b>															90000		
<b>TOTAL PRESENT USE DATA</b>																	